

MODEL :		TYPE
PROJECT :		
PREPARED BY :	DATE :	

SERIES SPECIFICATIONS

STEEL COMPRESSION CONNECTOR 1/2"



LINE DRAWING

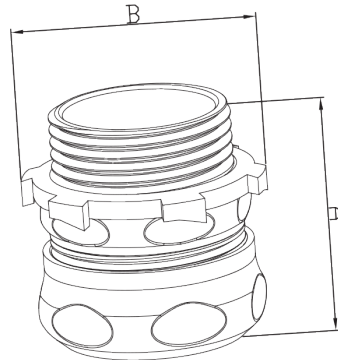

CONSTRUCTION

Material
SPCC cold rolled steel

Finish
Zinc Electro-Plated

Trade Size
1/2"

Connector
EMT Compression Connector

DIMENSION

A (In.)
1.37"

A (mm)
34.8mm

B (In.)
1.126"

B (mm)
28.6mm

Pipe Size
1/2"

NPSM
1/2-14NPSM

APPLICATION AND PERFORMANCE SPECIFICATION INFORMATION IS SUBJECT TO CHANGE WITHOUT NOTIFICATION

MODEL :		TYPE
PROJECT :		
PREPARED BY :	DATE :	

ORDERING INFORMATION

Part Number: WI MEC-750

IMS Code: 0285-2814

APPLICATION AND PERFORMANCE SPECIFICATION INFORMATION IS SUBJECT TO CHANGE WITHOUT NOTIFICATION