

MODEL :		TYPE
PROJECT :		
PREPARED BY :	DATE :	

## SERIES SPECIFICATIONS

STEEL COMPRESSION CONNECTOR 1-1/4"



## LINE DRAWING

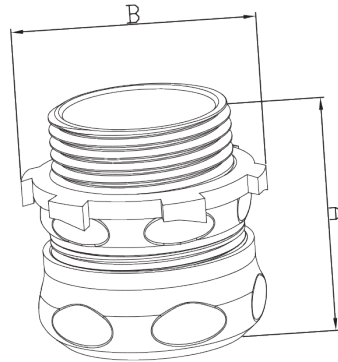

## CONSTRUCTION

Material  
SPCC cold rolled steel

Finish  
Zinc Electro-Plated

Trade Size  
1 1/4"

Connector  
EMT Compression Connector

## DIMENSION

A (In.)  
2.051"

A (mm)  
52.1mm

B (In.)  
2.059"

B (mm)  
52.3mm

Pipe Size  
1 1/4"

NPSM  
1 1/4-11.5NPSM

APPLICATION AND PERFORMANCE SPECIFICATION INFORMATION IS SUBJECT TO CHANGE WITHOUT NOTIFICATION

MODEL :		TYPE
PROJECT :		
PREPARED BY :	DATE :	

ORDERING INFORMATION

Part Number: WI MEC-753

IMS Code: 0285-2832

APPLICATION AND PERFORMANCE SPECIFICATION INFORMATION IS SUBJECT TO CHANGE WITHOUT NOTIFICATION