

MODEL :		TYPE
PROJECT :		
PREPARED BY :	DATE :	

SERIES SPECIFICATIONS

WI STL RT COMP CONN 1-1/2"



LINE DRAWING

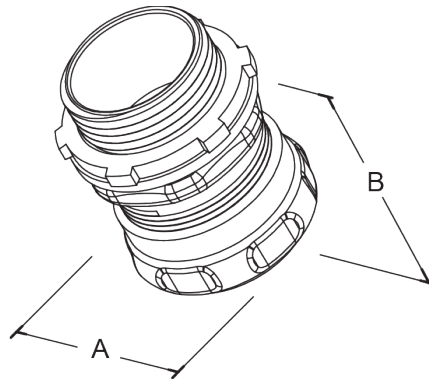

CONSTRUCTION

Material
Steel

Finish
Zinc plated

Trade Size
1 1/2"

Connector
EMT Raintight Compression Connector

Temperature Rating
105?

Sealing Ring Material
Zytel 103FHS

DIMENSION

A (In.)
2.37

A (mm)
60.19

B (In.)
2.41

B (mm)
61.21

APPLICATION AND PERFORMANCE SPECIFICATION INFORMATION IS SUBJECT TO CHANGE WITHOUT NOTIFICATION

MODEL :	TYPE	
PROJECT :		
PREPARED BY :	DATE :	

DIMENSION (Cont.)

Thread Size
1 1/2"-11.5

Trade Size
1 1/2"

ORDERING INFORMATION

Part Number: WI MECR-754

IMS Code: 2852928

Master Carton Qty: 20 PCS

Pallet Qty: 140 PCS

Master Carton Dimensions: 10.43x7.08x5.11In.

Pallet Dimensions: 45.28x37.4x41.73In.

Product Weight: 8.54Oz.

APPLICATION AND PERFORMANCE SPECIFICATION INFORMATION IS SUBJECT TO CHANGE WITHOUT NOTIFICATION