

MODEL :		TYPE
PROJECT :		
PREPARED BY :	DATE :	

## SERIES SPECIFICATIONS

WI SQUEEZE CONN 1-1/2"

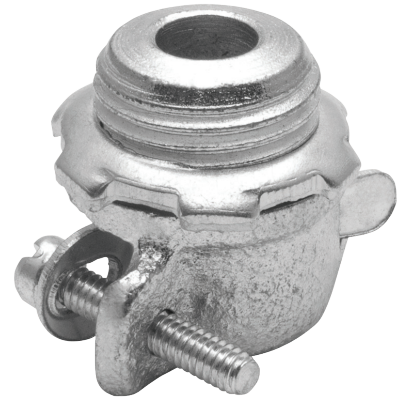

## LINE DRAWING

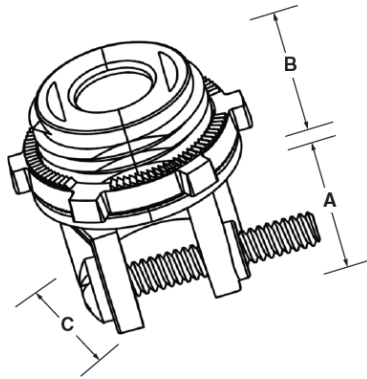

## CONSTRUCTION

Material  
Malleable Iron

Finish  
Zinc Plated

Trade Size  
1-1/2"

## DIMENSION

A (In.)  
1-7/8"

B (In.)  
5/8"

C (In.)  
2-1/4"

APPLICATION AND PERFORMANCE SPECIFICATION INFORMATION IS SUBJECT TO CHANGE WITHOUT NOTIFICATION

MODEL :		TYPE
PROJECT :		
PREPARED BY :		DATE :

## ORDERING INFORMATION

Part Number: WI ML42-5

IMS Code: 2853090

APPLICATION AND PERFORMANCE SPECIFICATION INFORMATION IS SUBJECT TO CHANGE WITHOUT NOTIFICATION



404 NW ENTERPRISE DR. PORT ST. LUCIE, FL 34986 | 772.408.5213 | WWW.CENTAURINSTALLATION.COM