

MODEL :		TYPE
PROJECT :		
PREPARED BY :	DATE :	

SERIES SPECIFICATIONS

WI SQUEEZE CONN 2-1/2"

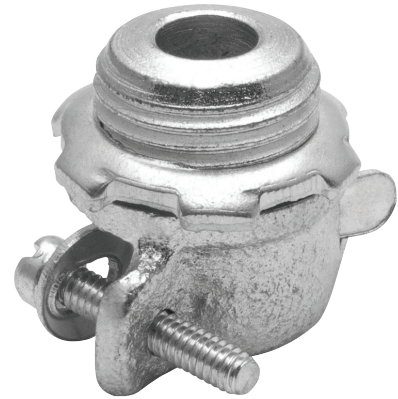

LINE DRAWING

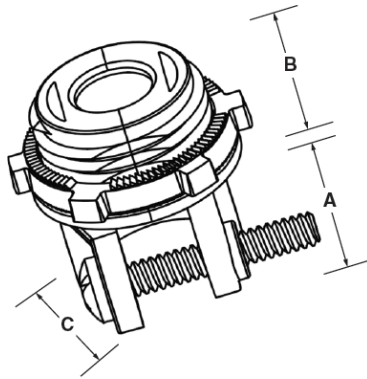

CONSTRUCTION

Material
Malleable Iron

Finish
Zinc Plated and Painted

Trade Size
2-1/2"

DIMENSION

A (In.)
2-1/6"

B (In.)
7/8"

C (In.)
3-5/16"

APPLICATION AND PERFORMANCE SPECIFICATION INFORMATION IS SUBJECT TO CHANGE WITHOUT NOTIFICATION

MODEL :		TYPE
PROJECT :		
PREPARED BY :	DATE :	

ORDERING INFORMATION

Part Number: WI ML42-7

IMS Code: 2853096

APPLICATION AND PERFORMANCE SPECIFICATION INFORMATION IS SUBJECT TO CHANGE WITHOUT NOTIFICATION



404 NW ENTERPRISE DR. PORT ST. LUCIE, FL 34986 | 772.408.5213 | WWW.CENTAURINSTALLATION.COM