

| | | | |
|---------------|--|--------|------|
| MODEL : | | | TYPE |
| PROJECT : | | | |
| PREPARED BY : | | DATE : | |

SERIES SPECIFICATIONS

CONDUIT NIPPLE ZINC DIE CAST 2"



LINE DRAWING

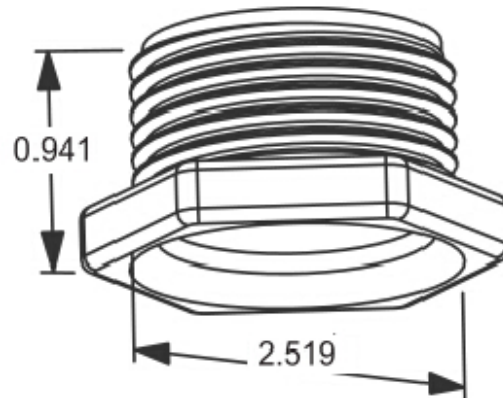

CONSTRUCTION

Material
Zinc Die Cast

Federal Spec
A-A-50553

DIMENSION

Trade Size
2

Hexagonal Length (In.)
2.519

Length (In.)
0.941

ORDERING INFORMATION

Part Number: WI L-706

Package Qty: 10 PCS

IMS Code: 0293-7594

APPLICATION AND PERFORMANCE SPECIFICATION INFORMATION IS SUBJECT TO CHANGE WITHOUT NOTIFICATION