

MODEL :			TYPE
PROJECT :			
PREPARED BY :		DATE :	

## SERIES SPECIFICATIONS

CONDUIT NIPPLE ZINC DIE CAST 3"



## LINE DRAWING

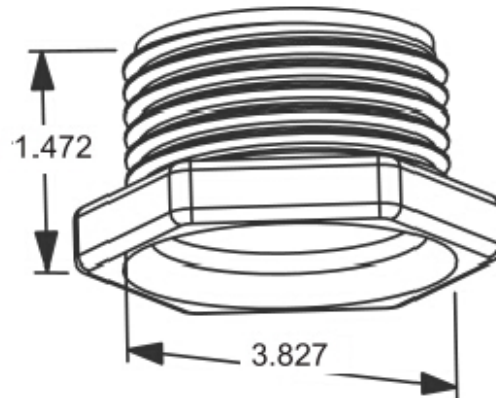

## CONSTRUCTION

Material  
Zinc Die Cast

Federal Spec  
A-A-50553

## DIMENSION

Trade Size  
3

Hexagonal Length (In.)  
3.827

Length (In.)  
1.472

## ORDERING INFORMATION

Part Number: WI L-708

Package Qty: 10 PCS

IMS Code: 0293-7600

APPLICATION AND PERFORMANCE SPECIFICATION INFORMATION IS SUBJECT TO CHANGE WITHOUT NOTIFICATION