

MODEL :		TYPE
PROJECT :		
PREPARED BY :	DATE :	

SERIES SPECIFICATIONS

CONDUIT NIPPLE ZINC DIE CAST 3"



LINE DRAWING

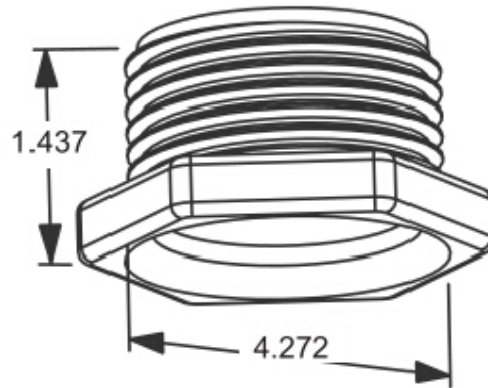

CONSTRUCTION

Material
Zinc Die Cast

Federal Spec
A-A-50554

DIMENSION

Trade Size
3 1/2

Hexagonal Length (In.)
4.272

Length (In.)
1.437

ORDERING INFORMATION

Part Number: WI L-709

Package Qty: 10 PCS

IMS Code: 0293-7603

APPLICATION AND PERFORMANCE SPECIFICATION INFORMATION IS SUBJECT TO CHANGE WITHOUT NOTIFICATION