

MODEL :		TYPE
PROJECT :		
PREPARED BY :	DATE :	

SERIES SPECIFICATIONS

CONDUIT NIPPLE ZINC DIE CAST 4"



LINE DRAWING

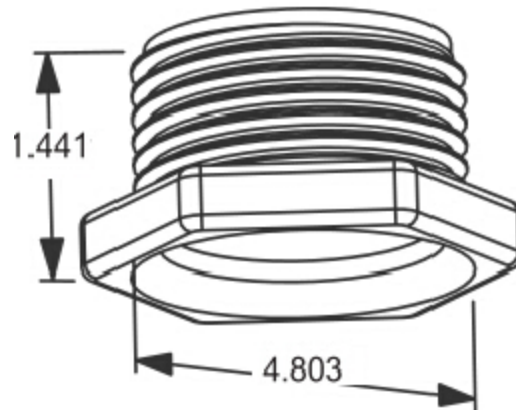

CONSTRUCTION

Material
Zinc Die Cast

Federal Spec
A-A-50553

DIMENSION

Trade Size
4

Hexagonal Length (In.)
4.803

Length (In.)
1.441

ORDERING INFORMATION

Part Number: WI L-710

Package Qty: 5 PCS

IMS Code: 0293-7606

APPLICATION AND PERFORMANCE SPECIFICATION INFORMATION IS SUBJECT TO CHANGE WITHOUT NOTIFICATION