

CONTRACTOR	
PROJECT	DATE
PREPARED BY	MODEL : WI MES-75 B

## SERIES SPECIFICATIONS

Centaur's uninsulated set screw electrical connectors are used in dry locations to bond EMT thinwall conduits to electrical junction boxes or enclosures. Uninsulated steel set screw connectors provide concrete tight connections when taped and properly secured with the included locknut, and are rated for electrical applications above 600 volts. Their heavy gauge steel construction maintains mechanical protection and solid grounding of the conduit to the designated electrical junction box or enclosure. Additionally, set screw connectors are zinc electroplated for excellent corrosion protection.



## LINE DRAWING

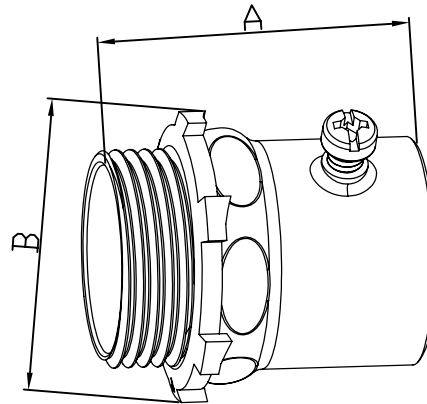

## CONSTRUCTION

Body Material  
Steel

Color  
Galvanized

Finish  
Zinc Electro-plated

## CERTIFICATIONS/WARRANTY

Listing  
UL Listed

Location Rating:  
Suitable for Damp locations

APPLICATION AND PERFORMANCE SPECIFICATION INFORMATION IS SUBJECT TO CHANGE WITHOUT NOTIFICATION

CONTRACTOR	
PROJECT	DATE
PREPARED BY	MODEL : WI MES-75 B

## ORDERING INFORMATION

Catalog Number	Trade Size.	A IN.	B IN	IMS Code
WI MES-750B	1/2"	1.472	1.126	0295-1226
WI MES-751B	3/4"	1.575	1.378	0295-1229
WI MES-752B	1"	1.862	1.717	0295-1232
WI MES-753B	1 1/4"	2.236	2.059	0295-1235
WI MES-754B	1 1/2"	2.236	2.374	0295-1238
WI MES-755B	2"	2.354	2.886	0295-1241
WI MES-756B	2 1/2"	2.945	3.441	0295-1244
WI MES-757B	3"	2.953	4.110	0295-1247
WI MES-758B	3 1/2"	3.228	4.673	0295-1250
WI MES-759B	4"	3.307	5.236	0295-1253

APPLICATION AND PERFORMANCE SPECIFICATION INFORMATION IS SUBJECT TO CHANGE WITHOUT NOTIFICATION