

CONTRACTOR	
PROJECT	DATE
PREPARED BY	MODEL : CM-BHA-16

SERIES SPECIFICATIONS

Centaur's Adjustable Bar Hangers are used to install electrical boxes that offset from stud walls. They are constructed from 16 gauge zinc plated steel. They are adjustable from 11" to 18" with notches for mounting boxes with self tapping screws. Ends bend and wrap around stud.



LINE DRAWING

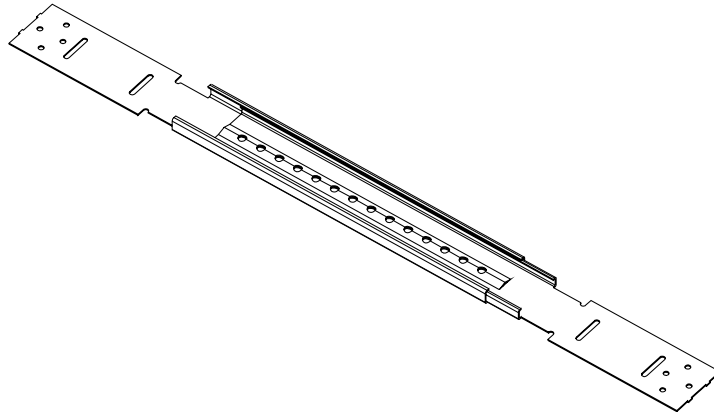

CONSTRUCTION

Material
Zinc Plated Steel

For Use With
1 1/2" or 2 1/8" deep boxes

Size
11" to 18"

CERTIFICATIONS

Listing
UL Listed

Fire Rating
Acceptable for use in 2-hour fire rated walls.

APPLICATION AND PERFORMANCE SPECIFICATION INFORMATION IS SUBJECT TO CHANGE WITHOUT NOTIFICATION

CONTRACTOR	
PROJECT	DATE
PREPARED BY	MODEL : CM-BHA-16

ORDERING INFORMATION

Part Number: CM-BHA-16

Case Dimensions (in.): 18.7x6.1x4.13

Case Quantity: 50 PCS

Item Weight (lbs.): 0.46

Case Weight (lbs.): 24..5

UPC BARCODES

	GTIN-12	GTIN-14	IMS Code
CM-BHA-16	190010380572	00190010380572	0262-7961

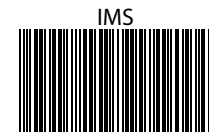

0262796101128012



1 90010 38057 2

APPLICATION AND PERFORMANCE SPECIFICATION INFORMATION IS SUBJECT TO CHANGE WITHOUT NOTIFICATION