

CONTRACTOR	
PROJECT	DATE
PREPARED BY	MODEL : CM-FSDB

## SERIES SPECIFICATIONS

The Centaur ceiling fan and light fixture support box is an ideal choice for installation during new construction or remodeling. It features an all steel, 21.5 cu. in., direct-mount electrical box. The 2 1/8" deep box comes standard with slide select 8-32 threads for cover plates and light weight fixtures as well as 10-24 threads for ceiling fans and heavy fixtures and will support fans up to 70lbs. and light fixtures up to 150lbs. The steel protective cover eliminates debris or damage to wiring.



## LINE DRAWING

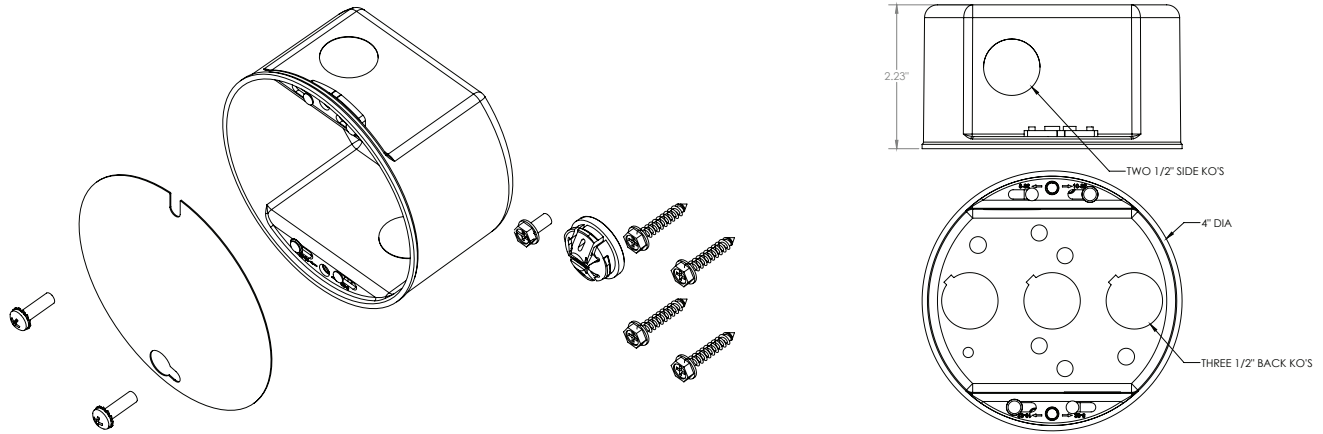

## CONSTRUCTION

### Material

Steel

### Application

New Construction and Remodel

### Installation Direction

Direct

### Cover

Protective Steel

## PHYSICAL SPECIFICATIONS

### Material Thickness

1/16"

### Number of Back Knockouts

3

### Number of Side Knockouts

2

### Overall Depth

2.23"

### Back Knockouts Size

1/2"

### Side Knockouts

1/2"

APPLICATION AND PERFORMANCE SPECIFICATION INFORMATION IS SUBJECT TO CHANGE WITHOUT NOTIFICATION

CONTRACTOR	
PROJECT	DATE
PREPARED BY	MODEL : CM-FSDB

## PHYSICAL SPECIFICATIONS CONT.

### Appliance Mounting

Slide Select 8-32 and  
10-32 Screw Holes

### Diameter

4"

### Max Fixture Weight

150 lbs.

### Ground Screw

10-24

### CU.IN

5.9

### Trade Size

1/2"

### Max Fan Weight

70 lbs.

## CERTIFICATIONS/WARRANTY

### Listing

UL Listed

### NEC Code

Meets or Exceeds

### Location Rating:

Suitable for Dry locations

### Warranty

Guaranteed for one year from the purchase date of the product, against mechanical defects in manufacturing.

## ORDERING INFORMATION

**Part Number:** CM-FSDB

**Case Dimensions (mm):** 330.2x228.6x76.2

**Case Dimensions (in.):** 13x9x3

**Case Quantity:** 12 PCS

## UPC BARCODES

	GTIN-12	GTIN-14	IMS Code
CM-FSDB	190010380008	00190010380008	0262-8057

