

CONTRACTOR	
PROJECT	DATE
PREPARED BY	MODEL : CM-FSDB-FB

SERIES SPECIFICATIONS

The Centaur ceiling fan and light fixture support box with side mount bracket is an ideal choice for installation during new construction or re-modeling. It features an all steel, 21.5 cu. in., direct-mount electrical box. The 2 1/8" deep box comes standard with slide select 8-32 threads for cover plates and light weight fixtures as well as 10-24 threads for ceiling fans and heavy fixtures and will support fans up to 70lbs. and light fixtures up to 150lbs. The steel protective cover eliminates debris or damage to wiring.



LINE DRAWING

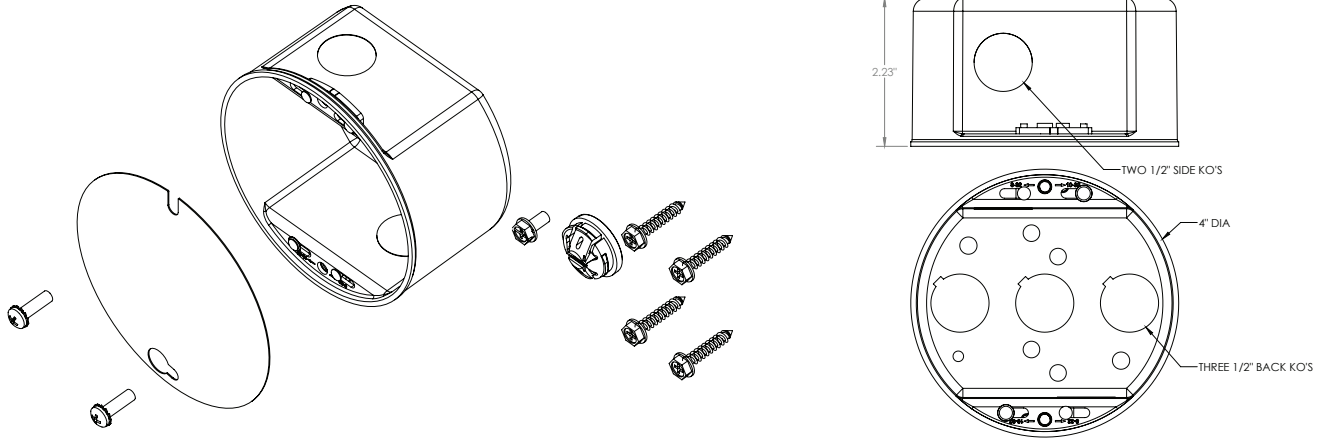

CONSTRUCTION

Material

Steel

Application

New Construction and Remodel

Installation Direction

Side

Cover

Protective Steel

PHYSICAL SPECIFICATIONS

Material Thickness

1/16"

Number of Back Knockouts

3

Number of Side Knockouts

2

Overall Depth

2.23"

Back Knockout Size

1/2"

Side Knockouts

1/2"

APPLICATION AND PERFORMANCE SPECIFICATION INFORMATION IS SUBJECT TO CHANGE WITHOUT NOTIFICATION

CONTRACTOR	
PROJECT	DATE
PREPARED BY	MODEL : CM-FSDB-FB

PHYSICAL SPECIFICATIONS CONT.

Appliance Mounting

Slide Select 8-32 and
10-32 Screw Holes

Diameter

4"

Max Fixture Weight

150 lbs.

Ground Screw

10-24

CU.IN

21.5

Trade Size

2-1/8"

Max Fan Weight

70 lbs.

CERTIFICATIONS/WARRANTY

Listing

UL Listed

NEC Code

Meets or Exceeds

Location Rating:

Suitable for Dry locations

Warranty

Guaranteed for One Year from the purchase date of the product, against mechanical defects in manufacturing.

ORDERING INFORMATION

Part Number: CM-FSDB-FB

Case Dimensions (mm): 225.04x114.05x110.99

Case Dimensions (in.): 8.86x4.49x4.37

Case Quantity: 12 PCS

UPC BARCODES

	GTIN-12	GTIN-14	IMS Code
CM-FSDB-FB	190010380060	00190010380060	0262-8060

