

MODEL :		TYPE
PROJECT :		
PREPARED BY :	DATE :	

SERIES SPECIFICATIONS

SQ. U-BOLT STRUT TO BEAM CLAMP FOR 2-7/16" & 3-1/4" CHAN



LINE DRAWING

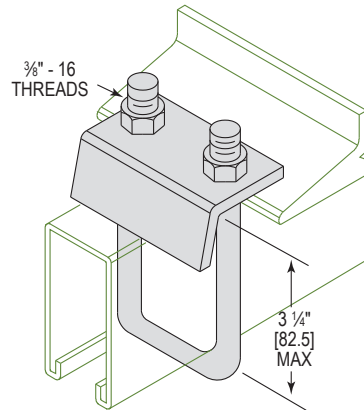

CONSTRUCTION

Finish
Electro-galvanized

Type
Square U-Bolt

DIMENSION

Threads
3/8" - 16

Channel Size
2 7/16" to 3 1/4"

Design Load (Lbs.)
1200

Design Load (kN)
5.34

APPLICATION AND PERFORMANCE SPECIFICATION INFORMATION IS SUBJECT TO CHANGE WITHOUT NOTIFICATION

MODEL :		TYPE
PROJECT :		
PREPARED BY :	DATE :	

ORDERING INFORMATION

Part Number: SBCLAMP1

Weight (lbs.): 0.79

IMS Code: 0304-8315

APPLICATION AND PERFORMANCE SPECIFICATION INFORMATION IS SUBJECT TO CHANGE WITHOUT NOTIFICATION