

MODEL :		TYPE
PROJECT :		
PREPARED BY :	DATE :	

SERIES SPECIFICATIONS

3 HOLE SWIVEL PLATE

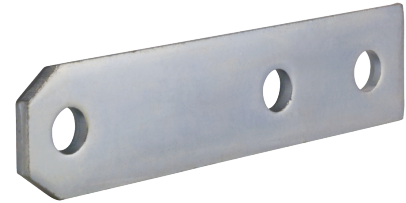

LINE DRAWING

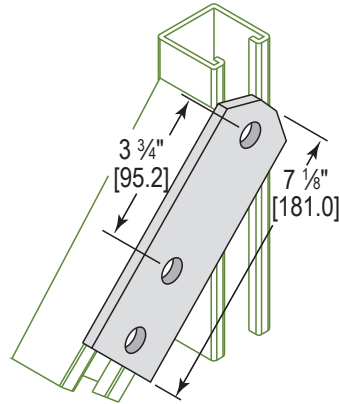

CONSTRUCTION

Type
Swivel

Finish
Electro-galvanized

of Holes
3

DIMENSION

Width (In.)
1 5/8"

Hole Spacing
3 3/4"

Length (In.)
7 1/8"

Thickness (mm.)
1/4"

APPLICATION AND PERFORMANCE SPECIFICATION INFORMATION IS SUBJECT TO CHANGE WITHOUT NOTIFICATION

MODEL :		TYPE
PROJECT :		
PREPARED BY :	DATE :	

ORDERING INFORMATION

Part Number: F41

Weight (lbs.): 0.53

IMS Code: 0304-8519

APPLICATION AND PERFORMANCE SPECIFICATION INFORMATION IS SUBJECT TO CHANGE WITHOUT NOTIFICATION