

MODEL :		TYPE
PROJECT :		
PREPARED BY :	DATE :	

SERIES SPECIFICATIONS

SQ. WASHER 3/8"

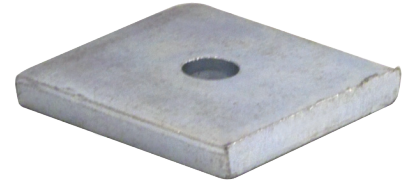

LINE DRAWING

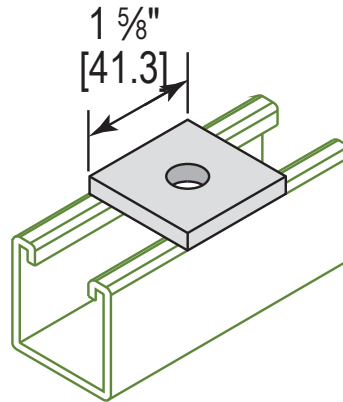

CONSTRUCTION

Finish
304 stainless steel

DIMENSION

Bolt Size (In.)
3/8"

Bolt Size (mm.)
8

Hole Size (In.)
7/16"

Hole Size (mm.)
11.1

Length (In.)
1-5/8"

Thickness (mm.)
1/4"

APPLICATION AND PERFORMANCE SPECIFICATION INFORMATION IS SUBJECT TO CHANGE WITHOUT NOTIFICATION

MODEL :		TYPE
PROJECT :		
PREPARED BY :	DATE :	

ORDERING INFORMATION

Part Number: SW37S4

Weight (lbs.): 0.17

IMS Code: 0304-9026

APPLICATION AND PERFORMANCE SPECIFICATION INFORMATION IS SUBJECT TO CHANGE WITHOUT NOTIFICATION