

MODEL :		TYPE
PROJECT :		
PREPARED BY :	DATE :	

## SERIES SPECIFICATIONS

SQ. WASHER 3/4"

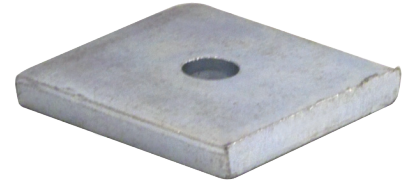

## LINE DRAWING

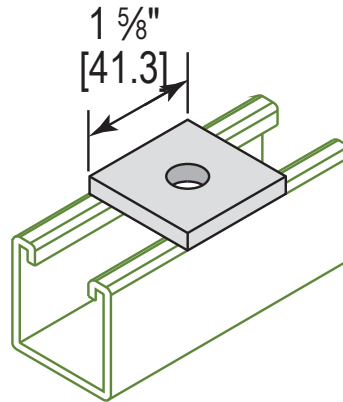

## CONSTRUCTION

Finish  
304 stainless steel

## DIMENSION

Bolt Size (In.)  
3/4"

Bolt Size (mm.)  
20

Hole Size (In.)  
13/16"

Hole Size (mm.)  
20.6

Length (In.)  
1-5/8"

Thickness (mm.)  
1/4"

APPLICATION AND PERFORMANCE SPECIFICATION INFORMATION IS SUBJECT TO CHANGE WITHOUT NOTIFICATION

MODEL :	TYPE
PROJECT :	
PREPARED BY :	DATE :

ORDERING INFORMATION

Part Number: SW75S4

Weight (lbs.): 0.14

IMS Code: 0304-9035

APPLICATION AND PERFORMANCE SPECIFICATION INFORMATION IS SUBJECT TO CHANGE WITHOUT NOTIFICATION