

MODEL :		TYPE
PROJECT :		
PREPARED BY :	DATE :	

## SERIES SPECIFICATIONS

SQ. WASHER 1/4"

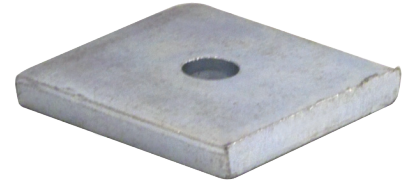

## LINE DRAWING

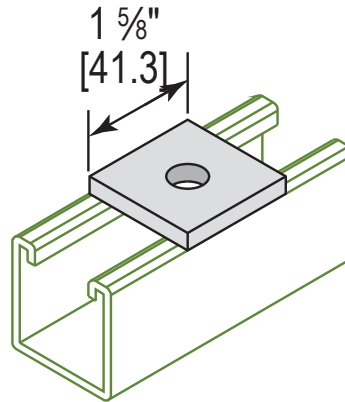

## CONSTRUCTION

Finish  
316 stainless steel

## DIMENSION

Bolt Size (In.)  
1/4"

Bolt Size (mm.)  
6

Hole Size (In.)  
5/16"

Hole Size (mm.)  
7.9

Length (In.)  
1-5/8"

Thickness (mm.)  
1/4"

APPLICATION AND PERFORMANCE SPECIFICATION INFORMATION IS SUBJECT TO CHANGE WITHOUT NOTIFICATION

MODEL :	TYPE
PROJECT :	
PREPARED BY :	DATE :

ORDERING INFORMATION

Part Number: SW25S6

Weight (lbs.): 0.18

IMS Code: 0305-5812

APPLICATION AND PERFORMANCE SPECIFICATION INFORMATION IS SUBJECT TO CHANGE WITHOUT NOTIFICATION