

CONTRACTOR:	
PROJECT:	DATE:
PREPARED BY:	SERIES: NUCB2400EG

NUCB2400EG

SPECIFICATION & FEATURES

DESCRIPTION

BRACKET CHANNEL NOTCHED UP 2 HL 24" EG

Country of Origin: US

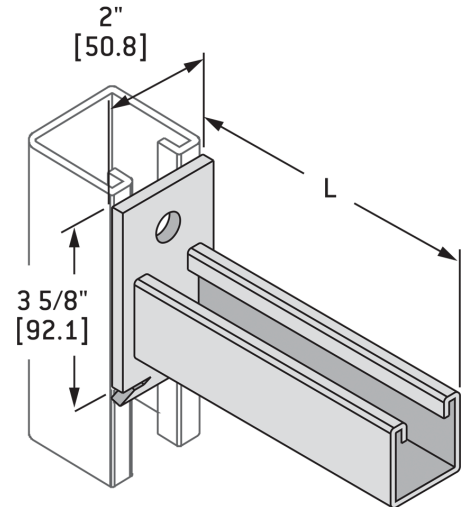

ORDERING INFORMATION

PART #	STOCK CODE	LENGTH	WIDTH	HEIGHT
NUCB2400EG	0305-8176	24 Inches	2 Inches	4.625 Inches
FINISH	MATERIAL	NUMBER OF BOLT HOLES		
ElectroGalvanized	Carbon Steel	2		

APPLICATION AND PERFORMANCE SPECIFICATION INFORMATION IS SUBJECT TO CHANGE WITHOUT NOTIFICATION