

CONTRACTOR:	
PROJECT:	DATE:
PREPARED BY:	SERIES: SWM050EG

# SWM050EG

## SPECIFICATION & FEATURES

### DESCRIPTION

SWIVEL MALE 1/2" EG

Country of Origin: US

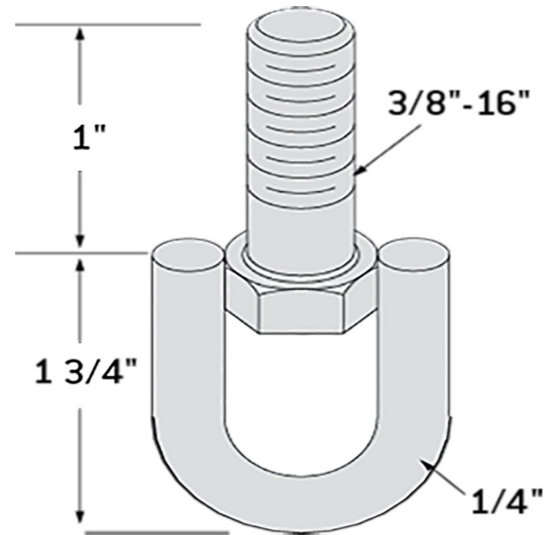

## ORDERING INFORMATION

PART #	STOCK CODE	LENGTH	HEIGHT	FINISH
SWM050EG	0305-8791	3 Inches	3 Inches	Electrogalvanized

MATERIAL	ROD SIZE (RS)	THREAD TYPE	THREAD PITCH/THREAD PER INCH
Carbon Steel		UNC	13