

CONTRACTOR:	
PROJECT:	DATE:
PREPARED BY:	SERIES: SWMF050EG

SWMF050EG

SPECIFICATION & FEATURES

DESCRIPTION

SWIVEL MALE-FEMALE 1/2" EG

Country of Origin: US

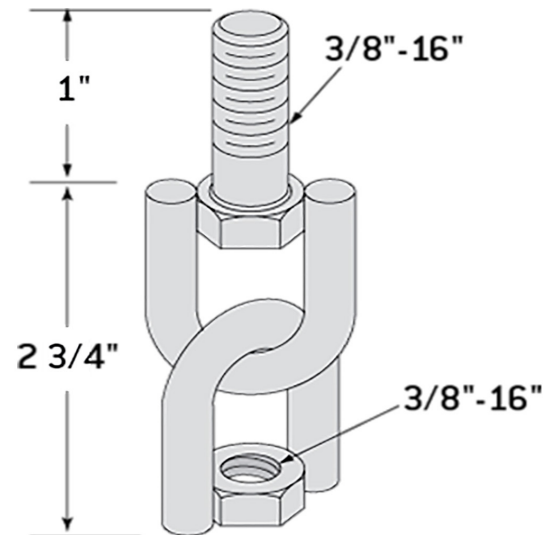

ORDERING INFORMATION

PART # SWMF050EG	STOCK CODE 0305-8797	LENGTH 3 Inches	HEIGHT 3 Inches	FINISH Electrogalvanized
----------------------------	--------------------------------	---------------------------	---------------------------	------------------------------------

MATERIAL Carbon Steel	ROD SIZE (RS) 1/2"-13	THREAD TYPE UNC	THREAD PITCH/THREAD PER INCH 13
---------------------------------	---------------------------------	---------------------------	-------------------------------------------