

| | |
|--------------|---------------------|
| CONTRACTOR: | |
| PROJECT: | DATE: |
| PREPARED BY: | SERIES: SCND25100EG |

SCND25100EG

SPECIFICATION & FEATURES

DESCRIPTION

1" STUD NUT REG SPRG 1/4"-20

Country of Origin: US

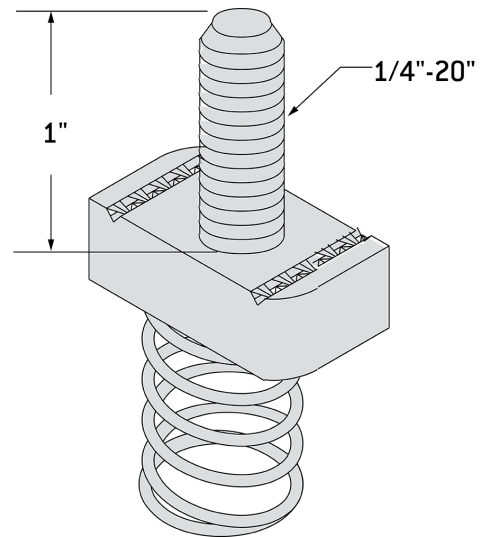

ORDERING INFORMATION

| | | | | |
|-----------------------------------|------------------------------------|------------------------------|-------------------------------------------------|--------------------------------------------|
| PART # SCND25100EG | STOCK CODE 0316-3209 | LENGTH 0.75 Inches | WIDTH 1.375 Inches | HEIGHT None |
| COLOR Gray | FINISH Electrogalvanized | MATERIAL Steel | MATERIAL OF CONSTRUCTION CARBON STEEL | NUT TYPE Stud Nut Regular Spring |
| SCREW SIZE 1/4" Inch-20 | THREAD SIZE 1/4-20 x 1 | THREAD TYPE UNC | | |

APPLICATION AND PERFORMANCE SPECIFICATION INFORMATION IS SUBJECT TO CHANGE WITHOUT NOTIFICATION