

CONTRACTOR:	
PROJECT:	DATE:
PREPARED BY:	SERIES: SCND25150EG

# SCND25150EG

## SPECIFICATION & FEATURES

### DESCRIPTION

1-1/2" STUD NUT REG SPRG 1/4"-20

Country of Origin: US

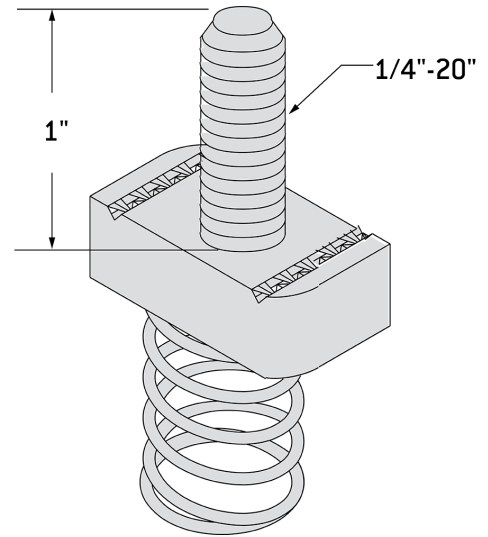

## ORDERING INFORMATION

<b>PART #</b> SCND25150EG	<b>STOCK CODE</b> 0316-3215	<b>LENGTH</b> 1.5 Inches	<b>WIDTH</b> None	<b>HEIGHT</b> None
<b>COLOR</b> Gray	<b>FINISH</b> Electrogalvanized	<b>MATERIAL</b> Steel	<b>MATERIAL OF CONSTRUCTION</b> CARBON STEEL	<b>NUT TYPE</b> Stud Nut Regular Spring
<b>SCREW SIZE</b> 1/4 Inch-20	<b>THREAD SIZE</b> 1/4-20 x 1 1/2	<b>THREAD TYPE</b> UNC		

APPLICATION AND PERFORMANCE SPECIFICATION INFORMATION IS SUBJECT TO CHANGE WITHOUT NOTIFICATION