

MODEL :		TYPE
PROJECT :		
PREPARED BY :	DATE :	

## SERIES SPECIFICATIONS

SERVICE ENT CAPS ALUM CLAMP-ON TYPE 1/2"



## LINE DRAWING

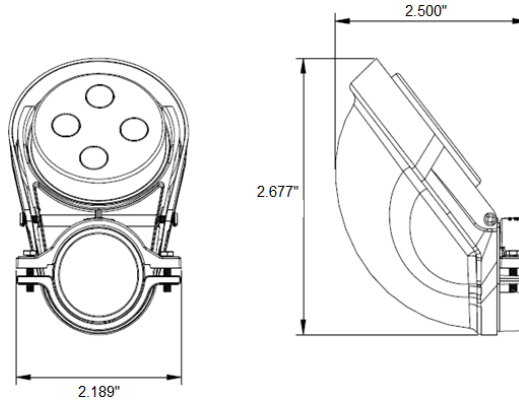

## CONSTRUCTION

Type  
Slip-fit Screw

## DIMENSION

Trade Size  
1/2

Height (In.)  
2.5

Pipe Size (In.)  
1/2"

Cap Width (In.)  
2.677

Clamp Width (In.)  
2.189

Screw Size  
8-32UNC X 0.35in or 12-24UNC X 1in

APPLICATION AND PERFORMANCE SPECIFICATION INFORMATION IS SUBJECT TO CHANGE WITHOUT NOTIFICATION

MODEL :		TYPE
PROJECT :		
PREPARED BY :	DATE :	

ORDERING INFORMATION

Part Number: WI 800-CL

Package Qty: 1 PCS

IMS Code: 0278-8200

APPLICATION AND PERFORMANCE SPECIFICATION INFORMATION IS SUBJECT TO CHANGE WITHOUT NOTIFICATION