

MODEL :		TYPE
PROJECT :		
PREPARED BY :	DATE :	

SERIES SPECIFICATIONS

SERVICE ENT CAPS ALUM CLAMP-ON TYPE 3/4"



LINE DRAWING

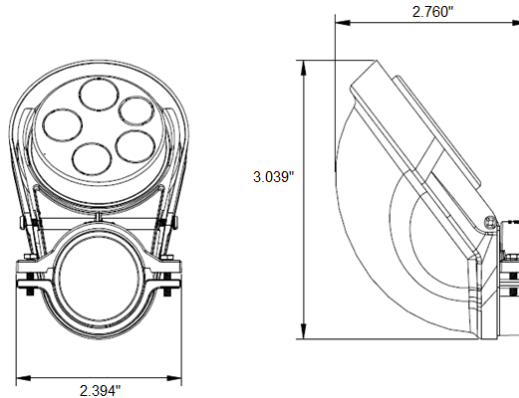

CONSTRUCTION

Type
Slip-fit Screw

DIMENSION

Trade Size
3/4

Height (In.)
2.76

Pipe Size (In.)
3/4"

Cap Width (In.)
3.039

Clamp Width (In.)
2.394

Screw Size
8-32UNC X 0.35in or 12-24UNC X 1in

APPLICATION AND PERFORMANCE SPECIFICATION INFORMATION IS SUBJECT TO CHANGE WITHOUT NOTIFICATION

MODEL :		TYPE
PROJECT :		
PREPARED BY :	DATE :	

ORDERING INFORMATION

Part Number: WI 801-CL

Package Qty: 1 PCS

IMS Code: 0278-8203

APPLICATION AND PERFORMANCE SPECIFICATION INFORMATION IS SUBJECT TO CHANGE WITHOUT NOTIFICATION