

MODEL :		TYPE
PROJECT :		
PREPARED BY :	DATE :	

SERIES SPECIFICATIONS

SERVICE ENT CAPS ALUM CLAMP-ON TYPE 1"



LINE DRAWING

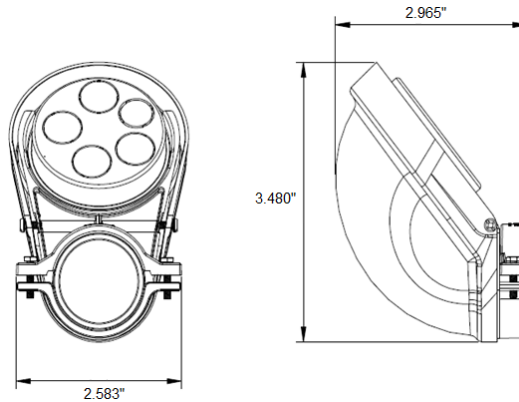

CONSTRUCTION

Type
Slip-fit Screw

DIMENSION

Trade Size
1

Height (In.)
2.965

Pipe Size (In.)
1"

Cap Width (In.)
3.48

Clamp Width (In.)
2.583

Screw Size
10-24UNC X 0.43in or 12-24UNC X 1in

APPLICATION AND PERFORMANCE SPECIFICATION INFORMATION IS SUBJECT TO CHANGE WITHOUT NOTIFICATION

MODEL :	TYPE	
PROJECT :		
PREPARED BY :	DATE :	

ORDERING INFORMATION

Part Number: WI 802-CL

Package Qty: 1 PCS

IMS Code: 0278-8206

APPLICATION AND PERFORMANCE SPECIFICATION INFORMATION IS SUBJECT TO CHANGE WITHOUT NOTIFICATION