

MODEL :		TYPE
PROJECT :		
PREPARED BY :	DATE :	

## SERIES SPECIFICATIONS

SERVICE ENT CAPS ALUM CLAMP-ON TYPE 1-1/2



## LINE DRAWING

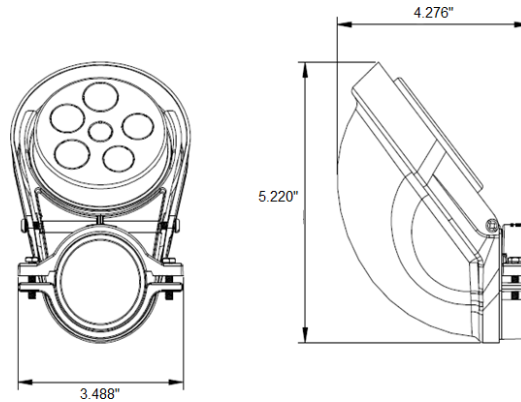

## CONSTRUCTION

Type  
Slip-fit Screw

## DIMENSION

Trade Size  
1 1/2

Height (In.)  
4.276

Pipe Size (In.)  
1 1/2"

Cap Width (In.)  
5.22

Clamp Width (In.)  
3.488

Screw Size  
10-24UNC X 0.43in or 12-24UNC X 1in

APPLICATION AND PERFORMANCE SPECIFICATION INFORMATION IS SUBJECT TO CHANGE WITHOUT NOTIFICATION

MODEL :		TYPE
PROJECT :		
PREPARED BY :	DATE :	

ORDERING INFORMATION

Part Number: WI 804-CL

Package Qty: 1 PCS

IMS Code: 0278-8212

APPLICATION AND PERFORMANCE SPECIFICATION INFORMATION IS SUBJECT TO CHANGE WITHOUT NOTIFICATION