

MODEL :		TYPE
PROJECT :		
PREPARED BY :	DATE :	

SERIES SPECIFICATIONS

SERVICE ENT CAPS ALUM CLAMP-ON TYPE 2"



LINE DRAWING

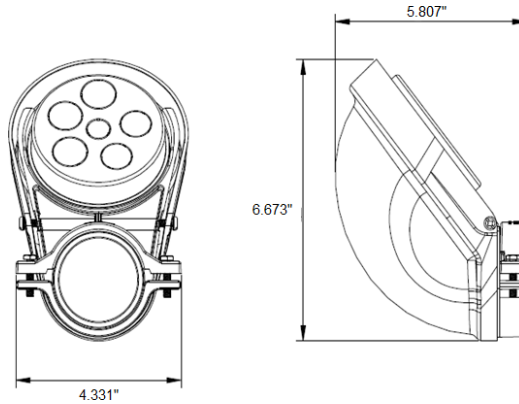

CONSTRUCTION

Type
Slip-fit Screw

DIMENSION

Trade Size
2

Height (In.)
5.807

Pipe Size (In.)
2"

Cap Width (In.)
6.673

Clamp Width (In.)
4.331

Screw Size
10-24UNC X 0.47in or 12-24UNC X 1in

APPLICATION AND PERFORMANCE SPECIFICATION INFORMATION IS SUBJECT TO CHANGE WITHOUT NOTIFICATION

MODEL :		TYPE
PROJECT :		
PREPARED BY :	DATE :	

ORDERING INFORMATION

Part Number: WI 805-CL

Package Qty: 1 PCS

IMS Code: 0278-8215

APPLICATION AND PERFORMANCE SPECIFICATION INFORMATION IS SUBJECT TO CHANGE WITHOUT NOTIFICATION