

MODEL :		TYPE
PROJECT :		
PREPARED BY :	DATE :	

SERIES SPECIFICATIONS

SERVICE ENT CAPS ALUM CLAMP-ON TYPE 2-1/2



LINE DRAWING

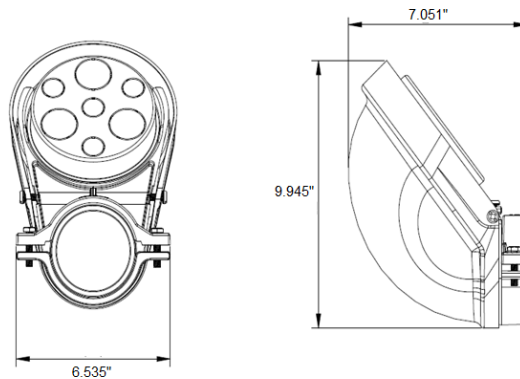

CONSTRUCTION

Type
Slip-fit Screw

DIMENSION

Trade Size
2 1/2

Height (In.)
7.051

Pipe Size (In.)
2 1/2"

Cap Width (In.)
9.945

Clamp Width (In.)
6.535

Screw Size
5/16-18UNC X 0.708in or 5/16-18UNC X 1.53in

APPLICATION AND PERFORMANCE SPECIFICATION INFORMATION IS SUBJECT TO CHANGE WITHOUT NOTIFICATION

MODEL :		TYPE
PROJECT :		
PREPARED BY :	DATE :	

ORDERING INFORMATION

Part Number: WI 806-CL

Package Qty: 1 PCS

IMS Code: 0278-8218

APPLICATION AND PERFORMANCE SPECIFICATION INFORMATION IS SUBJECT TO CHANGE WITHOUT NOTIFICATION