

MODEL :		TYPE
PROJECT :		
PREPARED BY :	DATE :	

SERIES SPECIFICATIONS

SERVICE ENT CAPS ALUM CLAMP-ON TYPE 4"



LINE DRAWING

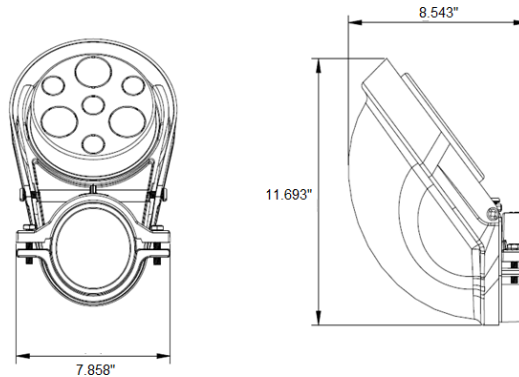

CONSTRUCTION

Type
Slip-fit Screw

DIMENSION

Trade Size
4

Height (In.)
8.543

Pipe Size (In.)
4"

Cap Width (In.)
11.693

Clamp Width (In.)
7.858

Screw Size
5/16-18UNC X 0.708in or 5/16-18UNC X 1.53in or
5/16-18UNC X 0.55in

APPLICATION AND PERFORMANCE SPECIFICATION INFORMATION IS SUBJECT TO CHANGE WITHOUT NOTIFICATION

MODEL :		TYPE
PROJECT :		
PREPARED BY :	DATE :	

ORDERING INFORMATION

Part Number: WI 809-CL

Package Qty: 1 PCS

IMS Code: 0278-8227

APPLICATION AND PERFORMANCE SPECIFICATION INFORMATION IS SUBJECT TO CHANGE WITHOUT NOTIFICATION