

MODEL :		TYPE
PROJECT :		
PREPARED BY :	DATE :	

SERIES SPECIFICATIONS

Double Gang Weatherproof Cover



LINE DRAWING

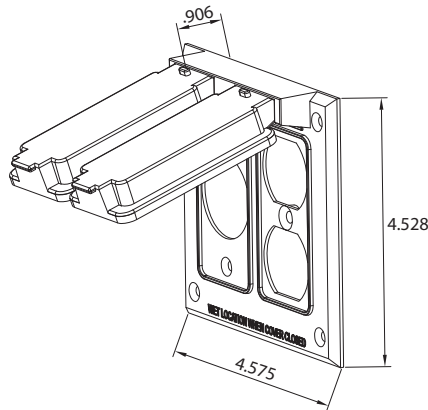

CONSTRUCTION

Material
Zinc Die Cast

Gang
2

Type
Weatherproof

Finish
Powder Coat

Color
Gray

Gasket
Included

DIMENSION

Width (In.)
4.575

Height (In.)
4.528

APPLICATION AND PERFORMANCE SPECIFICATION INFORMATION IS SUBJECT TO CHANGE WITHOUT NOTIFICATION

MODEL :	TYPE
PROJECT :	
PREPARED BY :	DATE :

ORDERING INFORMATION

Part Number: WI FC291

Package Qty: 15 PCS

IMS Code: 0278-8326

APPLICATION AND PERFORMANCE SPECIFICATION INFORMATION IS SUBJECT TO CHANGE WITHOUT NOTIFICATION