

MODEL :		TYPE
PROJECT :		
PREPARED BY :	DATE :	

SERIES SPECIFICATIONS

1 Gang Weatherproof Twist Lock Cover



LINE DRAWING

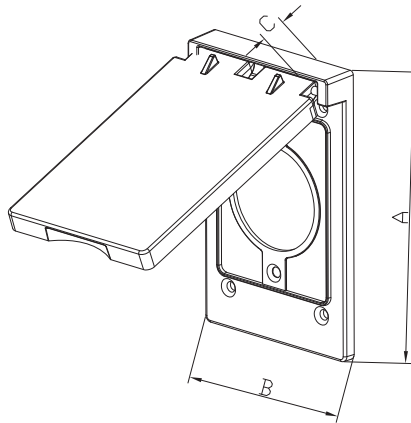

CONSTRUCTION

Material
Die Cast Zinc

Gang
1

Type
Twist Lock Cover

Finish
Gray

Screw Size
(2) 6-32UNC X 0.5 in

Amperage
20A

DIMENSION

A (In.)
4.587"

A (mm)
116.5mm

B (In.)
2.835"

B (mm)
72mm

APPLICATION AND PERFORMANCE SPECIFICATION INFORMATION IS SUBJECT TO CHANGE WITHOUT NOTIFICATION

MODEL :		TYPE
PROJECT :		
PREPARED BY :	DATE :	

DIMENSION

C (In.)
0.571"

C (mm)
14.5mm

ORDERING INFORMATION

Part Number: WI PO16

IMS Code: 0278-9535

APPLICATION AND PERFORMANCE SPECIFICATION INFORMATION IS SUBJECT TO CHANGE WITHOUT NOTIFICATION