

MODEL :		TYPE
PROJECT :		
PREPARED BY :	DATE :	

SERIES SPECIFICATIONS

3 gang GFCI receptacle cover for use whenever weatherproof protection is required for an outdoor receptacle.

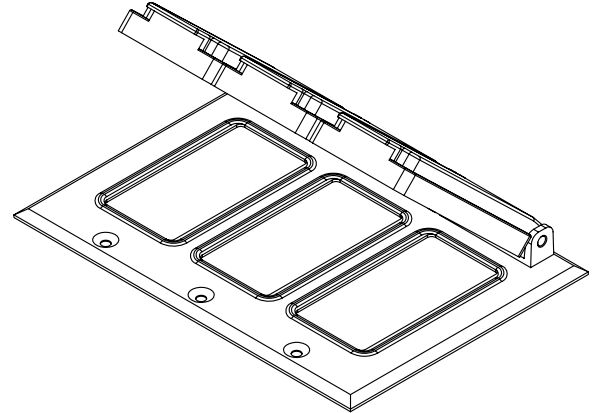

LINE DRAWING

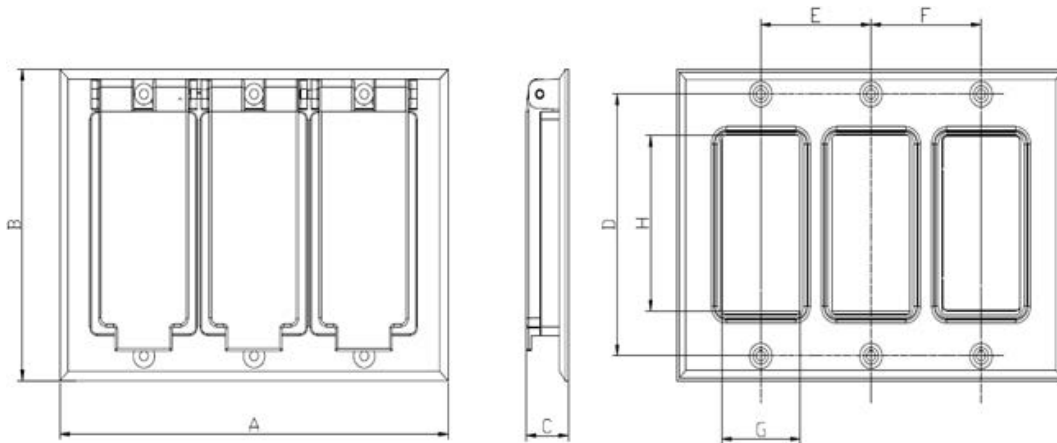

CONSTRUCTION

Base Material
Stamped Aluminum

Receptacle Type
GFCI

Gangs
3

Cover Material
Zinc Die Cast

Finish
Powdercoat Finish

Color
Gray

Mounting Screws
6

Gasket
Included

Mounting Style
Device Mounted

DIMENSIONS

A (+/- 0.02)
6.417"

B (+/- 0.02)
4.543"

C (+/- 0.02)
0.695"

D (+/- 0.01)
3.811"

E (+/- 0.01)
1.815"

F (+/- 0.01)
1.815"

APPLICATION AND PERFORMANCE SPECIFICATION INFORMATION IS SUBJECT TO CHANGE WITHOUT NOTIFICATION

MODEL :		TYPE
PROJECT :		
PREPARED BY :	DATE :	

DIMENSIONS (Cont.)

G (+/- 0.015)
1.318"

H (+/- 0.015)
2.634"

Screw Size
6-32UNC x 1/2"

CERTIFICATIONS/WARRANTY

Listing
UL Listed

Location Rating:
Suitable for Wet locations

ORDERING INFORMATION

Catalog Number	IMS Code
WI FGV3DC	0281-0583

APPLICATION AND PERFORMANCE SPECIFICATION INFORMATION IS SUBJECT TO CHANGE WITHOUT NOTIFICATION