

MODEL :		TYPE
PROJECT :		
PREPARED BY :	DATE :	

## SERIES SPECIFICATIONS

WI REDUCING WASHER 1-1/4" X 1"



## LINE DRAWING

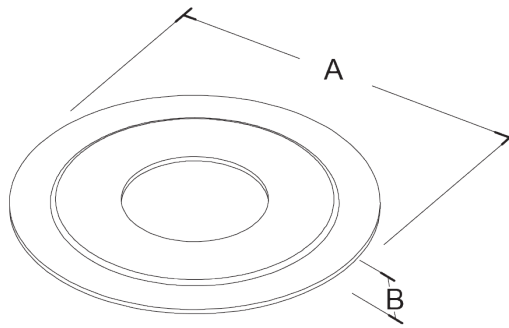

## CONSTRUCTION

Material  
Zinc Plated Steel

Finish  
Zinc Plated Steel

Flamability Rating  
Suitable for Dry locations

Trade Size  
1-1/4" X 1"

## DIMENSION

A (In.)  
2.19

A (mm)  
55.626

B (In.)  
0.05

B (mm)  
1.27

APPLICATION AND PERFORMANCE SPECIFICATION INFORMATION IS SUBJECT TO CHANGE WITHOUT NOTIFICATION

MODEL :		TYPE
PROJECT :		
PREPARED BY :	DATE :	

ORDERING INFORMATION

Part Number: WI MR7

IMS Code: 0284-3319

APPLICATION AND PERFORMANCE SPECIFICATION INFORMATION IS SUBJECT TO CHANGE WITHOUT NOTIFICATION