

MODEL :		TYPE
PROJECT :		
PREPARED BY :	DATE :	

SERIES SPECIFICATIONS

WI SQUEEZE CONN 3-1/2"

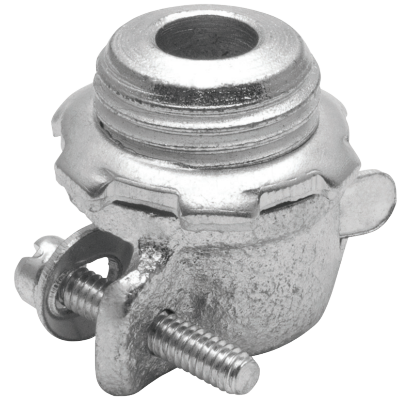

LINE DRAWING

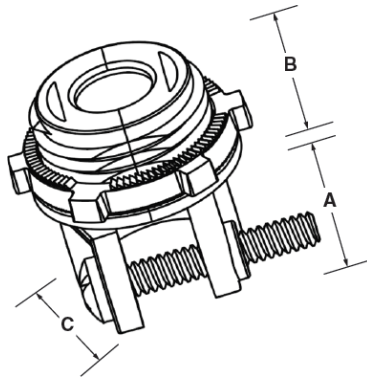

CONSTRUCTION

Material
Malleable Iron

Finish
Zinc Plated and Painted

Trade Size
3-1/2"

DIMENSION

A (In.)
3-3/4"

B (In.)
1-5/16"

C (In.)
6-1/2"

APPLICATION AND PERFORMANCE SPECIFICATION INFORMATION IS SUBJECT TO CHANGE WITHOUT NOTIFICATION

MODEL :		TYPE
PROJECT :		
PREPARED BY :		DATE :

ORDERING INFORMATION

Part Number: WI ML42-9

IMS Code: 2853102

APPLICATION AND PERFORMANCE SPECIFICATION INFORMATION IS SUBJECT TO CHANGE WITHOUT NOTIFICATION



404 NW ENTERPRISE DR. PORT ST. LUCIE, FL 34986 | 772.408.5213 | WWW.CENTAURINSTALLATION.COM