

CONTRACTOR	
PROJECT	DATE
PREPARED BY	MODEL :

## SERIES SPECIFICATIONS

3" X 2" FABRICATED PVC SWEDGE REDUCER COUPLING



## LINE DRAWING

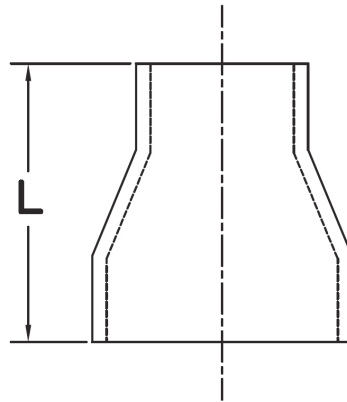

## CONSTRUCTION

**Material**

PVC

**Color**

Gray

**Size**

3 x 2"

**Length (in.)**

6.0"

## ORDERING INFORMATION

**Part Number:** SW32

**Item Weight (lbs.):** 0.298

APPLICATION AND PERFORMANCE SPECIFICATION INFORMATION IS SUBJECT TO CHANGE WITHOUT NOTIFICATION