

MODEL :		TYPE
PROJECT :		
PREPARED BY :	DATE :	

SERIES SPECIFICATIONS

CONDUIT NIPPLE ZINC DIE CAST 1/2"



LINE DRAWING

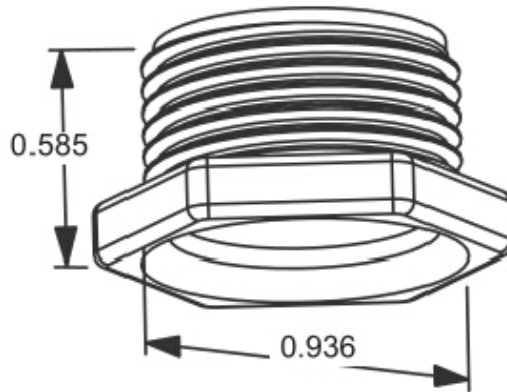

CONSTRUCTION

Material
Zinc Die Cast

Federal Spec
A-A-50553

DIMENSION

Trade Size
1/2

Hexagonal Length (In.)
0.936

Length (In.)
0.585

ORDERING INFORMATION

Part Number: WI L-701

Package Qty: 100 PCS

IMS Code: 0293-7579

APPLICATION AND PERFORMANCE SPECIFICATION INFORMATION IS SUBJECT TO CHANGE WITHOUT NOTIFICATION