

MODEL :		TYPE
PROJECT :		
PREPARED BY :	DATE :	

SERIES SPECIFICATIONS

CONDUIT NIPPLE ZINC DIE CAST 1-1/4"



LINE DRAWING

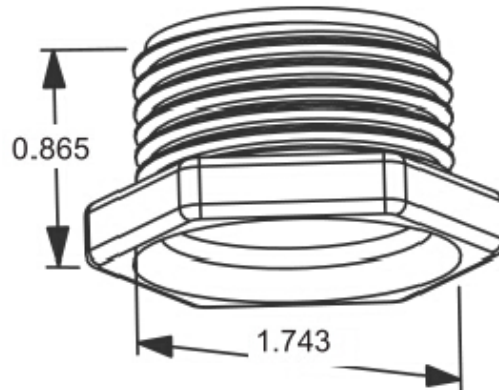

CONSTRUCTION

Material
Zinc Die Cast

Federal Spec
A-A-50553

DIMENSION

Trade Size
1 1/4

Hexagonal Length (In.)
1.743

Length (In.)
0.865

ORDERING INFORMATION

Part Number: WI L-704

Package Qty: 25 PCS

IMS Code: 0293-7588

APPLICATION AND PERFORMANCE SPECIFICATION INFORMATION IS SUBJECT TO CHANGE WITHOUT NOTIFICATION