

MODEL :			TYPE
PROJECT :			
PREPARED BY :		DATE :	

SERIES SPECIFICATIONS

CONDUIT NIPPLE ZINC DIE CAST 1-1/2"



LINE DRAWING

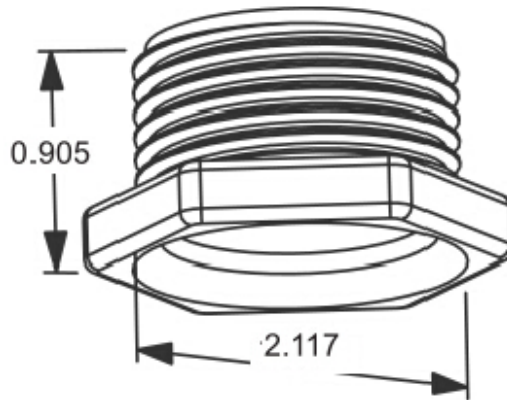

CONSTRUCTION

Material
Zinc Die Cast

Federal Spec
A-A-50553

DIMENSION

Trade Size
1 1/2

Hexagonal Length (In.)
2.117

Length (In.)
0.905

ORDERING INFORMATION

Part Number: WI L-705

Package Qty: 10 PCS

IMS Code: 0293-7591

APPLICATION AND PERFORMANCE SPECIFICATION INFORMATION IS SUBJECT TO CHANGE WITHOUT NOTIFICATION