

MODEL :		TYPE
PROJECT :		
PREPARED BY :	DATE :	

SERIES SPECIFICATIONS

ZINC DIE CAST SQUEEZE CONNECTOR 4"



LINE DRAWING

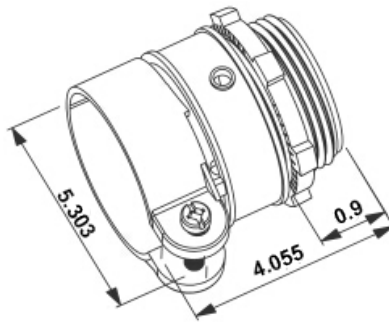

CONSTRUCTION

Material
Zinc Die-Cast

Type
Straight

Federal Spec
A-A-50552

DIMENSION

Trade Size
4

APPLICATION AND PERFORMANCE SPECIFICATION INFORMATION IS SUBJECT TO CHANGE WITHOUT NOTIFICATION

MODEL :		TYPE
PROJECT :		
PREPARED BY :	DATE :	

ORDERING INFORMATION

Part Number: WI L42-10

Package Qty: 1 PCS

IMS Code: 0294-2475

APPLICATION AND PERFORMANCE SPECIFICATION INFORMATION IS SUBJECT TO CHANGE WITHOUT NOTIFICATION