

CONTRACTOR	
PROJECT	DATE
PREPARED BY	MODEL : CM-4402

SERIES SPECIFICATIONS

Centaur's 4" Square Industrial covers, raised 1/2" are used to protect wires inside the box for switches, receptacles and outlets. They are constructed from 16 gauge galvanized steel. Centaur offers various cover designs for most applications. Selected models features crushed corners. All Centaur industrial covers are UL and RoHS listed.



LINE DRAWING

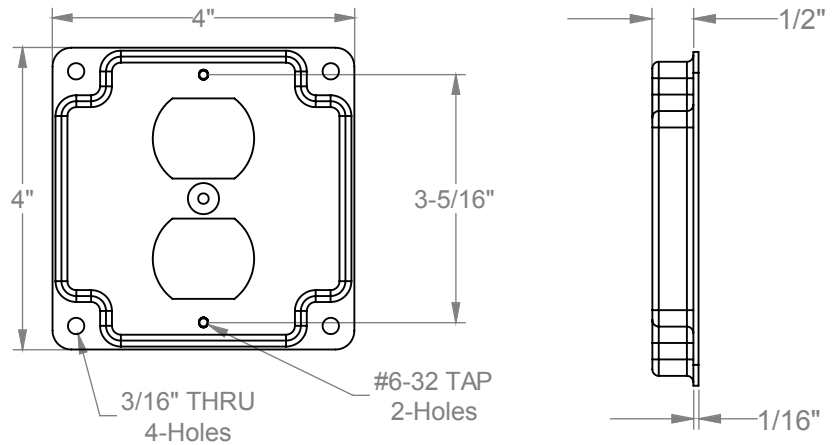
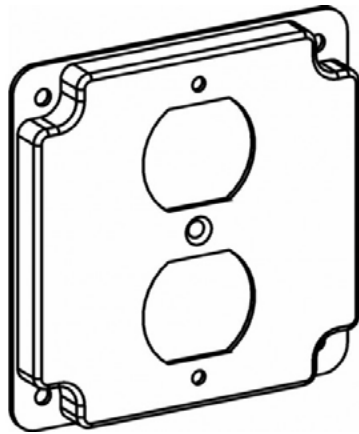

CONSTRUCTION

Material
Galvanized Steel

Make
Raised

Color
Galvanized

Volume
7 Cu. In.

Width
4"

Height
4"

Plate Type
Duplex Receptacle w/
Crushed Corners

CERTIFICATIONS

Listing
UL Listed

Fire Rating
Acceptable for use in 2-hour fire rated walls.

APPLICATION AND PERFORMANCE SPECIFICATION INFORMATION IS SUBJECT TO CHANGE WITHOUT NOTIFICATION

CONTRACTOR	
PROJECT	DATE
PREPARED BY	MODEL : CM-4402

ORDERING INFORMATION

Part Number: CM-4402

Case Dimensions (in.): ???

Case Quantity: 50 PCS

Item Weight (lbs.): ???

Case Weight (lbs.): 16.5

UPC BARCODES

	GTIN-12	GTIN-14	IMS Code
CM-4402	190010380213	00190010380213	0262-7412



APPLICATION AND PERFORMANCE SPECIFICATION INFORMATION IS SUBJECT TO CHANGE WITHOUT NOTIFICATION