



CENTAUR STEEL

635 NW Enterprise Dr. Port St Lucie, FL 34986

tel: (772) 344-9436 or on the web @ www.centaursteel.com

SPECIFICATION & FEATURES

Catalog Number
Notes
Job/Title

CM-4RDB-MKO

4" OCTAGON (40) WELDED DEEP BOXES 2-1/8" DEEP

DESCRIPTION:

Centaur Steel's 4" Octagon (40) Boxes are used in the installation of light fixtures and other electrical devices in walls and ceilings. They are constructed from 16 gauge galvanized steel. The 2-1/8" deep, welded boxes provide extra space for wires and devices. Selected models include an FB bracket for direct installations on studs.

CERTIFICATION:

UL file E227970, conforms to UL514A. acceptable for use in 2-hour fire rated walls.

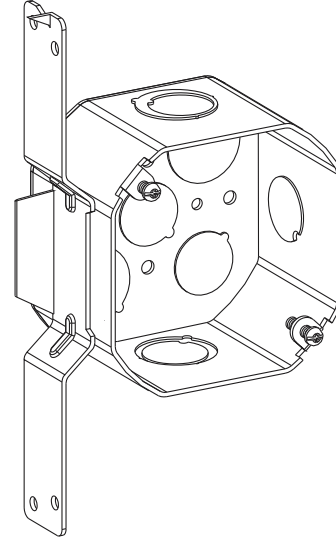

FEATURES

Knockout:

50: 1/2" K.O.

75: 3/4" K.O.

MKO: Moon K.O. (1/2" and 3/4" K.O.)

Bracket:

FB: (L: 7-1/4", W: 3/4") Offset (1/2") Mounts on flat side of stud or joist

Mfg. Process:

WELDED

DIMENSIONS

Diameter: 4"

Depth: 2-1/8"

Cu.In.: 21.5

CONFIGURATION DATA

Catalog No.	Bracket & Setback	Knockouts		Std. Pkg.
		Sides	Bottom	
CM-4RDB-MKO	-	(2)-1/2", (2)-MKO	(3)-1/2", (2)-3/4"	50
CM-4RDB-MKO-FB	FB, 1/2"	(1)-1/2", (2)-MKO	(3)-1/2", (2)-3/4"	25

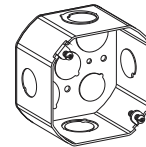

CM-4RDB-MKO

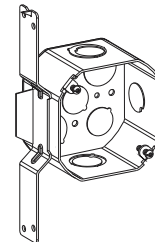

CM-4RDB-MKO-FB