



CENTAUR STEEL

635 NW Enterprise Dr. Port St Lucie, FL 34986

tel: (772) 344-9436 or on the web @ www.centaursteel.com
SPECIFICATION & FEATURES

| |
|----------------|
| Catalog Number |
| Notes |
| Job/Title |

CM-4RDB-NM

**4" OCTAGON (40) WELDED DEEP
 BOXES 2-1/8" DEEP WITH NM**

DESCRIPTION:

Centaur Steel's 4" Octagon (40) Welded Boxes are used in the installation of light fixtures, and other electrical devices. They are constructed from 16 gauge galvanized steel. The 2-1/8" deep, welded boxes provide extra space for wires and devices, and non-metallic sheathed cable clamp is included for ease of installation. Selected models include an FB Bracket for direct mounts on studs or an LB bracket with spurs.

CERTIFICATION:

UL file E227970, conforms to UL514A. acceptable for use in 2-hour fire rated walls.

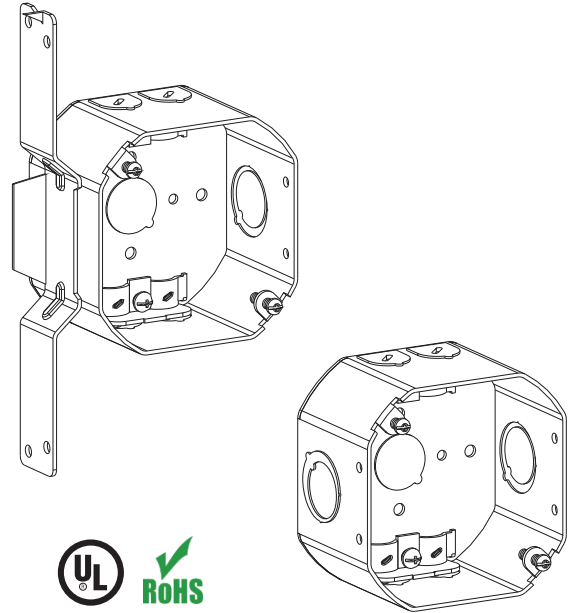

FEATURES

Knockout:

50: 1/2" K.O.

Loom: Loom Pryouts

MKO: Moon K.O. (1/2" and 3/4" K.O.)

Bracket:

FB: (L: 7-1/4", W: 3/4") Offset (1/2") Mounts on flat side of stud or joist

LB: (L: 2-3/8", W: 2-23/32") Offset (1/4") With spurs, slotted holes for toe-nailing.

Clamp:

NM: Accommodates #14-2 to #10-3 Non-Metallic Cables with ground

Mfg. Process:

WELDED

DIMENSIONS

Diameter: 4"

Depth: 2-1/8"

Cu.In.: 21.5

CONFIGURATION DATA

| Catalog No. | Bracket & Setback | Knockouts | | Std. Pkg. |
|---------------|-------------------|-------------------|----------|-----------|
| | | Sides | Bottom | |
| CM-4RDB-NM | - | (2)-MKO, (4)-Loom | (1)-1/2" | 50 |
| CM-4RDB-NM-FB | FB, 1/2" | (1)-MKO, (4)-Loom | (1)-1/2" | 25 |
| CM-4RDB-NM-LB | LB, 1/2" | (2)-MKO, (4)-Loom | (1)-1/2" | 25 |

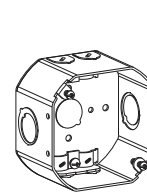

CM-4RDB-NM

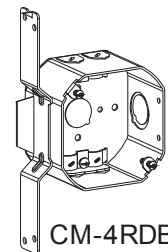

CM-4RDB-NM-FB

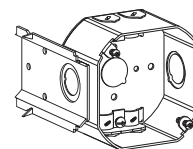

CM-4RDB-NM-LB