

MODEL :		TYPE
PROJECT :		
PREPARED BY :	DATE :	

SERIES SPECIFICATIONS

4" SQ. EXT., 1/2" DEEP, 1/2" & 3/4" K.O.

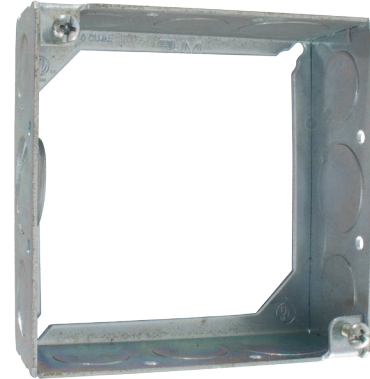

LINE DRAWING

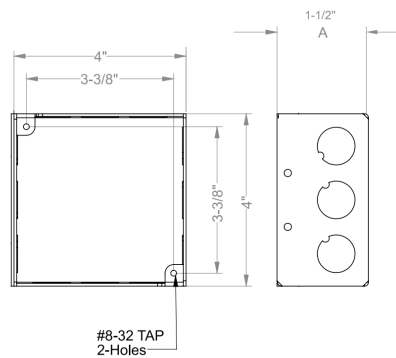

CONSTRUCTION

Material
16 Ga Sheet Steel

Mfg. Process
Welded

Finish
Galvanized

DIMENSIONS

Width (In.)
4

Height (In.)
4

Depth (In.)
1 1/2

KO Sides
Sides(8) - 1/2", (4) - 3/4"

KO Bottom
NA

MKO Knockout
NA

Cover Screw Spacing
3 3/8

Ground Screw Size
NA

Cubic In.
21

APPLICATION AND PERFORMANCE SPECIFICATION INFORMATION IS SUBJECT TO CHANGE WITHOUT NOTIFICATION

MODEL :		TYPE
PROJECT :		
PREPARED BY :	DATE :	

DIMENSIONS (Cont.)

Ground Emboss
NA

Cover Screw
8-32

Bracket
NA

ORDERING INFORMATION

Part Number: CM-4SB-50/75-EXT

Case Weight (lbs.): 25

Case Quantity: 50 PCS

APPLICATION AND PERFORMANCE SPECIFICATION INFORMATION IS SUBJECT TO CHANGE WITHOUT NOTIFICATION