

CONTRACTOR	
PROJECT	DATE
PREPARED BY	MODEL : CM-4SB-MC-B

SERIES SPECIFICATIONS

Centaur's 4" Square (4S) Boxes are used to install lighting fixtures, switches, and receptacles in ceilings and walls. They are constructed from 16 gauge galvanized steel. The 1-1/2" deep, welded boxes include non-metallic sheathed cable clamps for ease of installation. Selected models include metal stud brackets that engage on either side of a metal stud or a bracket to directly mount on a stud. All Centaur steel boxes are UL listed and acceptable for use in 2-hour fire rated walls.

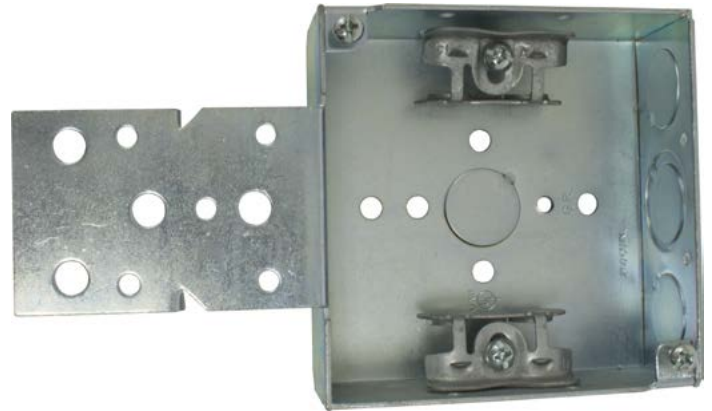

LINE DRAWING

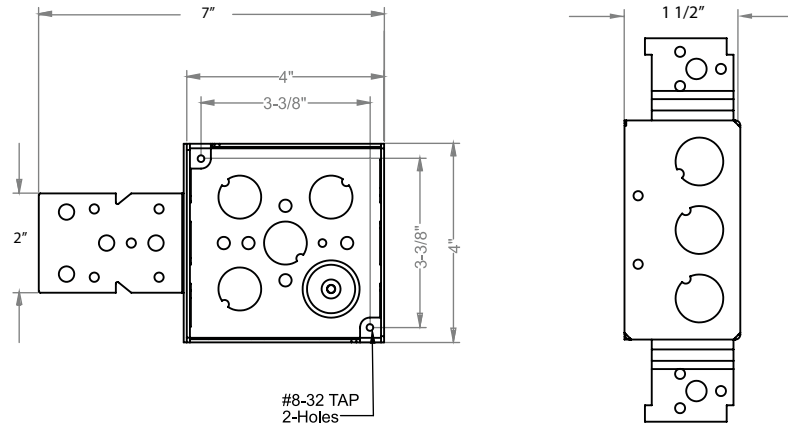
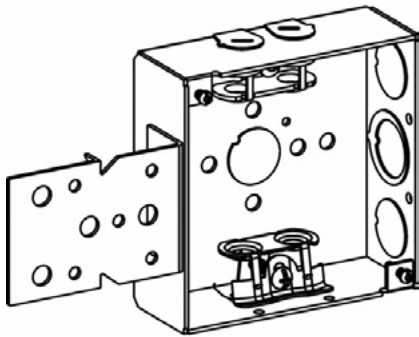

CONSTRUCTION

Material
Galvanized Steel

Make
Welded

Color
Galvanized

Material Thickness
16 Ga.

Knockout Sides
(2) 1/2", (1) MKO, (4) Loom

Knockout Bottom
(1) 1/2"

Bracket Type
B, Flush

Width
4"

Height
4"

Depth
1 1/2"

Volume
21 Cu. In.

Clamp Type
Metal Clad

Includes
MC Clamp for Metal Clad
Cables for easy installation

Bracket Details
(L: 3", W: 2") Offset (Flush)
Face mounts on front edge of
wood stud

Clamp Accommodates
#14-2 to #10-4 Metal Clad Ca-
bles.

APPLICATION AND PERFORMANCE SPECIFICATION INFORMATION IS SUBJECT TO CHANGE WITHOUT NOTIFICATION

CONTRACTOR	
PROJECT	DATE
PREPARED BY	MODEL : CM-4SB-MC-B

CERTIFICATIONS

Listing
UL Listed

Fire Rating
Acceptable for use in 2-hour fire rated walls.

ORDERING INFORMATION

Part Number: CM-4SB-MC-B

Case Dimensions (in.): ???

Case Quantity: 24 PCS

Item Weight (lbs.): ???

Case Weight (lbs.): 21.5

UPC BARCODES

	GTIN-12	GTIN-14	IMS Code
CM-4SB-MC-B	190010381098	00190010381098	0262-7814



0262781401127862



1 90010 38109 8

APPLICATION AND PERFORMANCE SPECIFICATION INFORMATION IS SUBJECT TO CHANGE WITHOUT NOTIFICATION