

MODEL :		TYPE
PROJECT :		
PREPARED BY :	DATE :	

## SERIES SPECIFICATIONS

4" SQ. BOX, 1-1/2". DEEP, M.K.O. - WELD

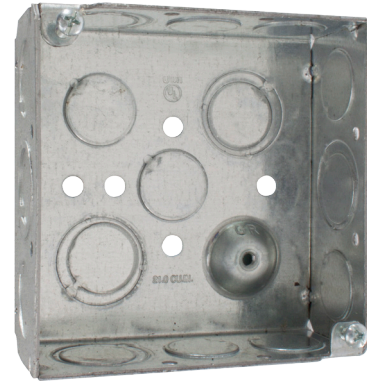

## LINE DRAWING

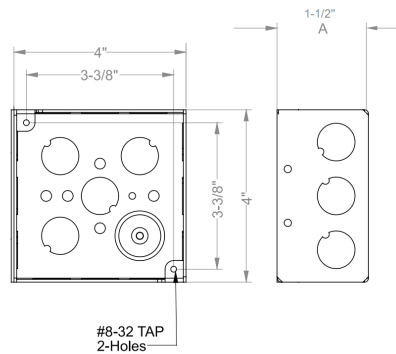

## CONSTRUCTION

Material  
16 Ga Sheet Steel

Mfg. Process  
Welded

Finish  
Galvanized

## DIMENSIONS

Width (In.)  
4

Height (In.)  
4

Depth (In.)  
1 1/2

KO Sides  
Sides(8) - 1/2", (4) - MKO

KO Bottom  
(2) - 1/2", (2) - MKO

MKO Knockout  
1/2" and 3/4"

Cover Screw Spacing  
3 3/8

Ground Screw Size  
10-32

Cubic In.  
21

APPLICATION AND PERFORMANCE SPECIFICATION INFORMATION IS SUBJECT TO CHANGE WITHOUT NOTIFICATION

MODEL :		TYPE
PROJECT :		
PREPARED BY :	DATE :	

### DIMENSIONS (Cont.)

Ground Emboss  
Raised

Cover Screw  
8-32

Bracket  
NA

### ORDERING INFORMATION

Part Number: CM-4SB-MKO

Case Weight (lbs.): 33

Case Quantity: 50 PCS

APPLICATION AND PERFORMANCE SPECIFICATION INFORMATION IS SUBJECT TO CHANGE WITHOUT NOTIFICATION