



CENTAUR STEEL

635 NW Enterprise Dr. Port St Lucie, FL 34986

tel: (772) 344-9436 or on the web @ www.centaursteel.com

SPECIFICATION & FEATURES

Catalog Number
Notes
Job/Title

SPECIFICATION & FEATURES

CM-4SDB

4" SQUARE WELDED DEEP BOXES 2-1/8" DEEP WITH NM

DESCRIPTION:

Centaur's 4" Square (4S) Deep Boxes are used to install lighting fixtures, switches, and receptacles in ceilings and walls. They are constructed from 16 gauge galvanized steel. These 2-1/8" deep, welded boxes include non-metallic sheathed cable clamps for ease of installation. Selected models include brackets to directly mount on a stud.

CERTIFICATION:

UL file E227970, conforms to UL514A. acceptable for use in 2-hour fire rated walls.

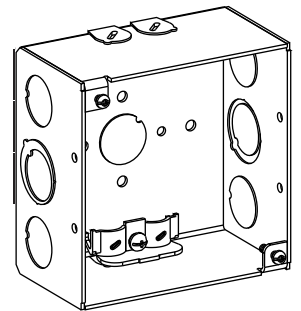
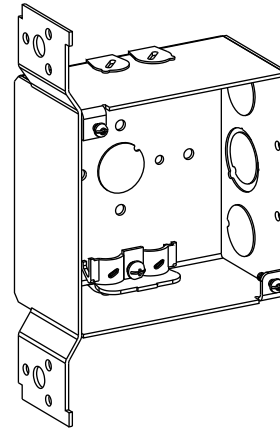

FEATURES

Knockout:

50: 1/2" K.O. ; Loom: Loom Pryouts ;

MKO: Moon K.O. (1/2" and 3/4" K.O.)

Bracket:

FB: (L: 7-3/8", W: 1-9/16") Offset (Flush) Mounts on flat side of stud

B: (L: 3", W: 2") Offset (Flush) Face mounts on front edge of wood stud

WB: (L: 7-1/2", W: 1-9/16") Offset (Flush) With positioning spurs to mount box on side of stud

Clamp:

NM: Accommodates #14-2 to #10-3 Non-Metallic Cables with ground

Mfg. Process:

WELDED

DIMENSIONS

Width: 4"

Height: 4"

Depth: 2-1/8"

Cu.In.: 30.3

CONFIGURATION DATA

Catalog No.	Bracket & Setback	Knockouts		Std. Pkg.
		Sides	Bottom	
CM-4SDB-NM	-	(4)-1/2", (2)-MKO, (4)-Loom	(1)-1/2"	24
CM-4SDB-NM-B	B, Flush	(2)-1/2", (1)-MKO, (4)-Loom	(1)-1/2"	24
CM-4SDB-NM-FB	FB, Flush	(2)-1/2", (1)-MKO, (4)-Loom	(1)-1/2"	24
CM-4SDB-NM-WB	WB, Flush	(2)-1/2", (1)-MKO, (4)-Loom	(1)-1/2"	24

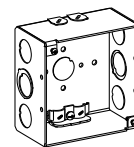

CM-4SDB-NM

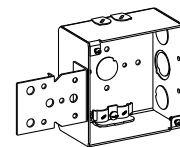

CM-4SDB-NM-B

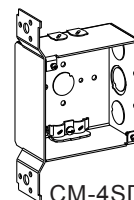

CM-4SDB-NM-FB

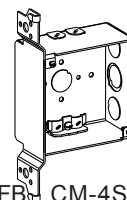

CM-4SDB-NM-WB