

CONTRACTOR	
PROJECT	DATE
PREPARED BY	MODEL : CM-GB-1

SERIES SPECIFICATIONS

Centaur's 2-1/2" Deep Gangable Switch Boxes are used in the installation of switches. They are constructed from 16 gauge galvanized steel. All Centaur steel boxes are UL listed and acceptable for use in 2-hour fire rated walls. Includes removable side cover for multigang applications.



LINE DRAWING

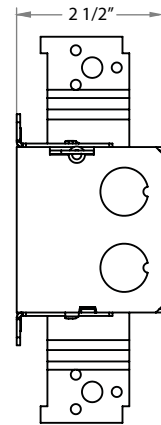
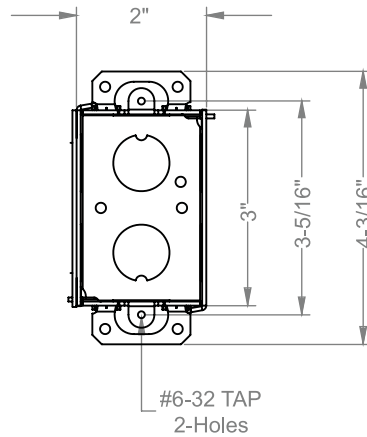
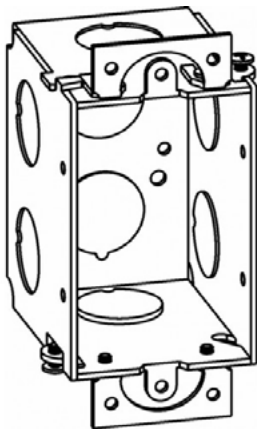

CONSTRUCTION

Material
Galvanized Steel

Make
Welded

Color
Galvanized

Material Thickness
16 Ga.

Width
2"

Height
3"

Depth
2 1/2"

Volume
12.5 Cu. In.

No. of Gangs
1, Gangable

Knockout Ends
(2) 1/2"

Knockout Sides
(4) 1/2"

Knockout Bottom
(2) 1/2"

APPLICATION AND PERFORMANCE SPECIFICATION INFORMATION IS SUBJECT TO CHANGE WITHOUT NOTIFICATION

CONTRACTOR	
PROJECT	DATE
PREPARED BY	MODEL : CM-GB-1

CERTIFICATIONS

Listing
UL Listed

Fire Rating
Acceptable for use in 2-hour fire rated walls.

ORDERING INFORMATION

Part Number: CM-GB-1

Case Dimensions (in.): ???

Case Quantity: 50 PCS

Item Weight (lbs.): ???

Case Weight (lbs.): 25.5

UPC BARCODES

	GTIN-12	GTIN-14	IMS Code
CM-GB-1	190010380411	00190010380411	0262-8066



APPLICATION AND PERFORMANCE SPECIFICATION INFORMATION IS SUBJECT TO CHANGE WITHOUT NOTIFICATION