

# SPECIFICATION & FEATURES

## DESCRIPTION:

Centaur's Deep Handy Boxes mount on the surface of the wall and are used in the installation of switches, receptacles, and other devices. They are constructed from 16 gauge galvanized steel. The welded, 2-1/8" deep boxes are deep to suit specific needs and include 1/2" knockouts. Selected models include an FB bracket to mount on the flat side of the stud and an AB bracket to mount on the face and side of the stud.

## CERTIFICATION:

UL file E227970, conforms to UL514A. acceptable for use in 2-hour fire rated walls.

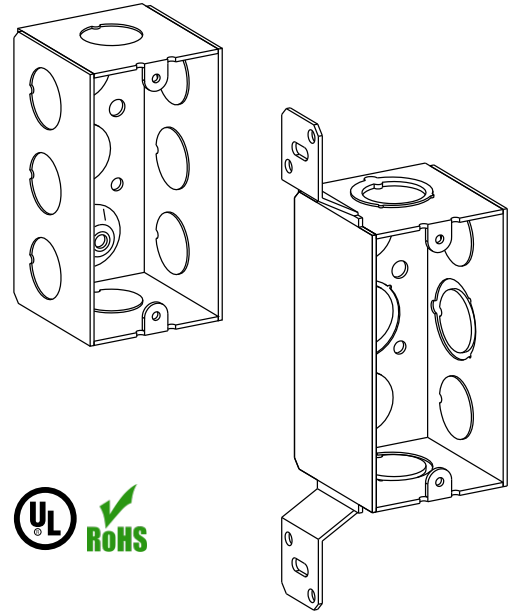

## FEATURES

### Knockout:

50: 1/2" K.O.;

MKO: Moon K.O. (1/2" and 3/4" K.O.)

### Bracket:

FB: (L: 7", W: 1") Offset (9/16") Mounts on flat side of stud

AB: 90° (L: 5-7/8", W: 7/8") Offset (9/16") Positions box against face and side of stud

Mfg. Process:

WELDED

## DIMENSIONS

Width: 2"

Height: 4"

Depth: 2-1/8"

Cu.In.: 16.5

## CONFIGURATION DATA

Catalog No.	Bracket & Setback	Knockouts		Std. Pkg.
		Sides	Bottom	
CM-HDB-1-50	-	(8)-1/2"	(2)-1/2"	50
CM-HDB-1-50-FB	FB, 9/16"	(5)-1/2"	(3)-1/2"	50
CM-HDB-1-MKO	-	(4)-1/2", (4)-MKO	(1)-1/2", (1)-MKO	50
CM-HDB-1-MKO-AB	AB, 9/16"	(2)-1/2", (3)-MKO	(2)-1/2", (1)-MKO	50
CM-HDB-1-MKO-FB	FB, 9/16"	(2)-1/2", (3)-MKO	(2)-1/2", (1)-MKO	50

