

MODEL :		TYPE
PROJECT :		
PREPARED BY :	DATE :	

SERIES SPECIFICATIONS

WINDOW TYPE STRUT TO BEAM CLAMP



LINE DRAWING

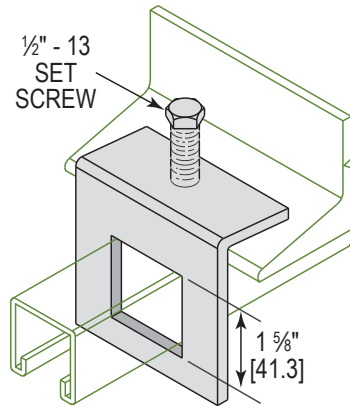

CONSTRUCTION

Finish
Electro-galvanized

Set Screw
1/2" - 13

Type
Window

DIMENSION

Material Thickness (In.)

-

Material Thickness (mm.)

-

Design Load (Lbs.)
950

Design Load (kN)
4.23

Max Flange Thickness

-

Length

-

APPLICATION AND PERFORMANCE SPECIFICATION INFORMATION IS SUBJECT TO CHANGE WITHOUT NOTIFICATION

MODEL :	TYPE
PROJECT :	
PREPARED BY :	DATE :

DIMENSION (Cont.)

Hole Opening
1 5/8"

ORDERING INFORMATION

Part Number: SBCW

Weight (lbs.): 1.06

IMS Code: 0304-8309

APPLICATION AND PERFORMANCE SPECIFICATION INFORMATION IS SUBJECT TO CHANGE WITHOUT NOTIFICATION